



914CE3-9



Actual product appearance may vary.

Miniature Enclosed Switches Series
914CE: Cross Roller Plunger (90°
Rotated Plunger); 1NC 1NO SPDT Snap
Action; 9 foot Cable

Features

- Compact construction
- Pre-wired or connector versions
- Die-cast Zinc housing
- Wide selection of actuators
- Gang mounting capability
- Cable length variations
- Side and bottom exit cable/connector
- Simple two-screw mounting
- Low temperature variants
- Fluorocarbon sealing (standard)

Potential Applications

- Processing Equipment
- Textile Machinery
- Machine Tools
- Robotics
- Packaging Equipment
- Farm Machinery
- Commercial Laundry Equipment
- Printing Trade Machinery
- Vehicles

Description

All MICRO SWITCH™ 14CE and 914CE series miniature enclosed switches incorporate fluorocarbon diaphragm sealing to provide reliable protection, meeting NEMA 1, 2, 3, 3R, 4, 6, 6P, and 13 as well as IP66, IP67, and IP68 requirements. Versions with boot seal also meet NEMA 12 requirements (dust, falling dirt, liquid media with solid contaminants). The cable or connector and basic switch terminals are encapsulated in an epoxy compound, offering superior resistance in harsh environments. For low temperature applications (down to -40 degrees C, -40 degrees F), CE switches can be supplied with low temperature seals and lubricant.

The CE switches are a rugged and versatile switch which can be applied indoors in harsh factory floor applications, as well as on outdoor equipment in extreme temperatures. A full range of actuators are available, including plain plungers, roller plungers, side rotary, multi-directional wire, and manually operated. The switches are also available with the industry standard, M12 miniature 4-pin connector. The MICRO SWITCH™ 14 CE versions are designed for European applications and meet the requirements of the low voltage directive and therefore carry the CE mark. The MICRO SWITCH™ 914CE products meet UL and CSA standards, as well as European CE requirements.

Product Specifications	
Availability	Global
Operating Force (O.F.)	11.8 N max. [2.65 lb max.]
Release Force (R.F.)	4.4 N max. [0.99 lb max.]
Pretravel (P.T.)	1.0 mm \pm 0.5 mm [0.04 in \pm 0.02 in]
Overtravel (O.T.)	3.0 mm min. [0.118 in min.]
Differential Travel (D.T.)	0.1 mm max. [0.004 in max.]
Product Type	MICRO SWITCH™ Miniature Limit Switches
Actuator	Cross Roller Plunger (90° Rotated Plunger)
Lever Style	None
Circuitry	1NC 1NO SPDT Snap Action
Ampere Rating	5 A (Thermal)
Supply Voltage	240 Vac
Housing Material	Zinc Die-Cast
Termination Type	9 foot Cable
Series Name	914CE
Sealing	IP66, IP67, IP68; NEMA 1, 2, 3, 3R, 4, 6, 6P, 13
Approvals	UL recognized, CSA Certified, CE Certified
CSA File #	LR15775
UL File #	E41859
Mechanical Life	up to 10 million
Operating Temperature Range	0 °C to 70 °C (35 °F to 160 °F)
Comment	Bottom Exit Cable
Agency Approvals and Standards	IEC947-5-1, EN60947-5-1
UNSPSC Code	302119
UNSPSC Commodity	302119 Switches and controls and relays
Sealed	Industrial

MICRO SWITCH

a Honeywell Division

FED. MFG. CODE 91929

MINIATURE PRECISION LIMIT SWITCH

CATALOG LISTING
914CE3-9

914CE3-9

M

DRAWING
NUMBER

5

ISSUE

REPLACES

RELEASE NO. ETS

CHECK

REVISIONS

A CO-69061
S A V
4 OCT 91

CHECK

13 NOV 91

DRAWN

CHECK

4 OCT 91

DDM/CAD

DRAWN

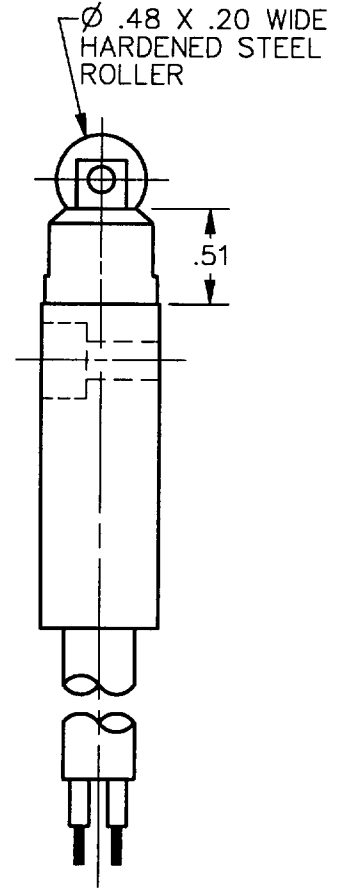
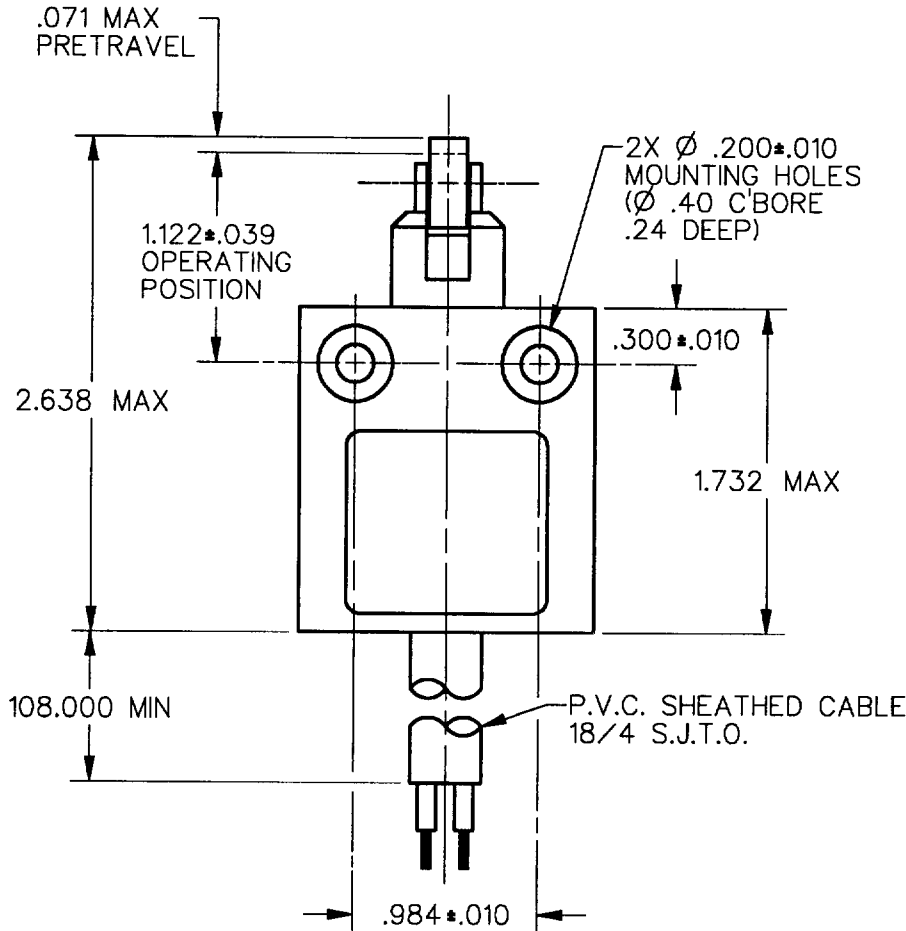
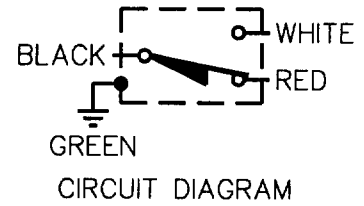
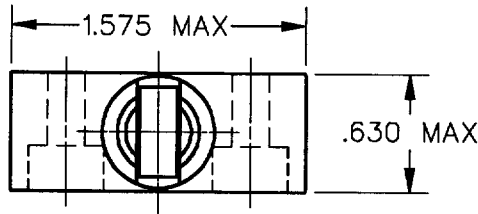

NOTES
1 - ZINC HOUSING FINISHED WITH GRAY PAINT

ANSI Y14.5M-1982 APPLIES

THIS DRAWING COVERS A PROPRIETARY ITEM AND IS THE PROPERTY OF MICRO SWITCH, A DIVISION OF HONEYWELL. THIS DRAWING IS NOT TO BE COPIED OR USED WITHOUT THE APPROVAL OF MICRO SWITCH.

THIRD ANGLE PROJECTION

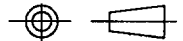

CHARACTERISTICS	
OPERATING FORCE	2.7 LB MAX
RELEASE FORCE	1.0 LB MIN
DIFFERENTIAL TRAVEL	.004 MAX
OVERTRAVEL	.118 MIN

ELECTRICAL DATA

CONTACT ARRANGEMENT
S P D T

5A - 250 VAC
1/10HP - 125 OR 250 VAC



SCALE	FULL	DO NOT SCALE PRINT
UNLESS OTHERWISE SPECIFIED TOLERANCES ARE		
ONE PLACE	(.0)	±.030
TWO PLACE	(.00)	±.015
THREE PLACE	(.000)	±.005
ANGLES		±
WEIGHT		